

MultiBeam-Laser MBL 5



060.020A / Rev 0305

LASERLINER®
Innovation in Tools

Ⓓ	Bedienungsanleitung	3-6
ⒼⒷ	Operating instructions	7-10
ⓃⓁ	Gebruiksaanwijzing	11-14
ⒹⓀ	Betjeningsvejledning	15-18
Ⓕ	Mode d'emploi	19-22
Ⓔ	Instrucciones para su uso	23-26
Ⓘ	Istruzioni d'uso	27-30
Ⓟ	Instrukcja Obsługi	31-34
ⒻⒾ	Käyttöohje	35-38

MultiBeam-Laser MBL 5

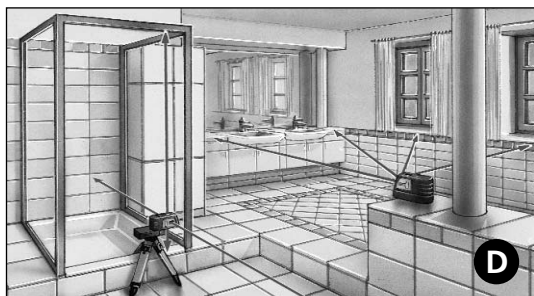
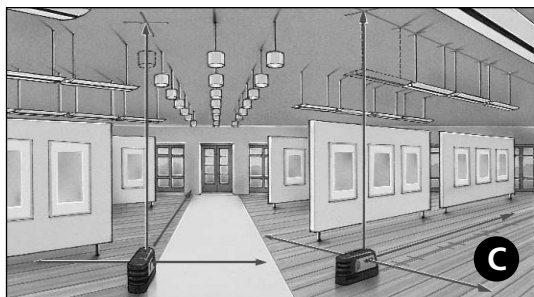

Ideal for aligning on all surfaces

Automatic 5-spot 635 nm laser with magnetically damped pendulum system. All 5 lasers are set at right angles to each other. This makes practically all alignment tasks possible. Additionally, the housing can be turned to enable horizontal levelling, while the two perpendicular lasers allow markings to be easily transferred from the floor to the ceiling. Precision 2 mm/ 10 m, self-levelling range 4° - 6°, optical signal when tolerance is exceeded. With the magnetic base, the device can be used everywhere - on building and photo tripods, on inside walls, steel structures, etc.

Includes: Magnetic base, Laser enhancement glasses, tightening belt, allen wrench, carrying case and batteries.

General safety instructions



LASER LIGHT
DO NOT LOOK INTO
THE BEAM!
CLASS 2 LASER
EN 60825-1:2001

Caution: Do not look directly into the beam. Lasers must be kept out of reach of children.

Never intentionally aim the device at people. This is a quality laser measuring device and is 100% factory adjusted within the stated tolerance. For reasons of product liability, we must also draw your attention to the following: Regularly check the calibration before use, after transport and after extended periods of storage.

Warranty

The warranty period is 2 years from the date of purchase. The warranty covers all material or manufacturing defects occurring during this time. The following is excluded from warranty: Damage due to improper use (e.g. operation with wrong type of current/voltage, connection to unsuitable power source, fall onto hard surface, etc.) or improper storage, normal wear and tear, and defects which only insignificantly impair the value or suitability for use. Any tampering by unauthorised persons will render this warranty void. In the event that you need to claim warranty, please take the complete device together with all information and the invoice to one of our dealers or send it in to Umarex-Laserliner.

Note:

This product is a precision instrument that must be handled and treated with care. Avoid shocks and impact. Always keep and carry in the case! Switch all lasers off and secure the pendulum. For cleaning, use a soft cloth and glass cleaner.

MultiBeam-Laser MBL 5

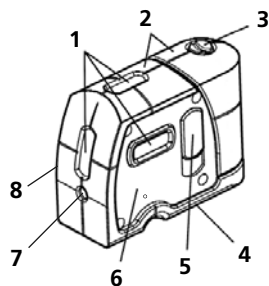

Magnetic base

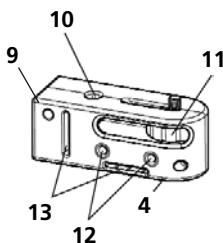

- | | |
|--|--|
| 1 Laser emitting window | 8 Side beam calibration port (Y-axis) |
| 2 Rubber grip housing | 9 Magnets |
| 3 Battery compartment-cover | 10 5/8" nut for connection to construction tripod (mount from bottom). |
| 4 1/4" nut for connection to camera tripod | 11 Connecting screw MultiBeam 5 |
| 5 ON / OFF-Switch
Pendulum lock | 12 Screw mounting holes (accepts standard drywall screws) |
| 6 Self-leveling pendulum (inside) | 13 Slot for tightening belt |

Battery replacement

Make sure the batteries are correctly poled!



Switch on

Assemble with connecting screw (11) MultiBeam-Laser 5 and magnetic base. Switch the unit on (5). The laser dots will be projected.

Applications (examples see P. 2)

- A Aligning
- B Horizontal levelling
- C Plumb line
- D Height projection

Note:

If the device is positioned too much out of level (more than 4° or 6°), the laser will blink. Position the device on a more level surface.

Case dimensions – laserbeams

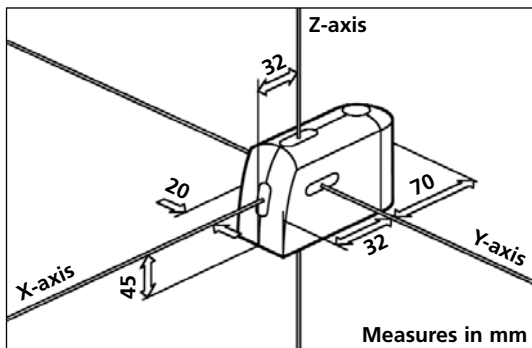

Technical Data

Automatic levelling range	side-side forward-backward	$\pm 4^\circ$ $\pm 6^\circ$
Accuracy		± 2 mm / 10 m
Operating range (depending on room illumination)		ca. 100 m
Power supply		3 x 1,5V AA / ca. 24 h
Laser wavelength		635 nm
Laser		Class 2 ≤ 1 mW
Weight		0,4 kg
Operating temperature		-10°C bis +50°C
Storage temperature		-20°C bis + 70°C
Order number		060.020A
Subject to technical changes without notice		04/2005

Note:

Regularly check the calibration before use, after transport and after extended periods of storage.

MultiBeam-Laser MBL 5

Preparing the calibration check

It is possible for you to check the calibration of the laser. To do this, position the device **midway** between 2 walls, which must be at least 5 metre apart. Switch the device on. The best calibration results are achieved if the device is mounted on a tripod.

- 1 Mark point A1 on the wall.
- 2 Turn the device 180° and mark point A2. You now have a horizontal reference between points A1 and A2.

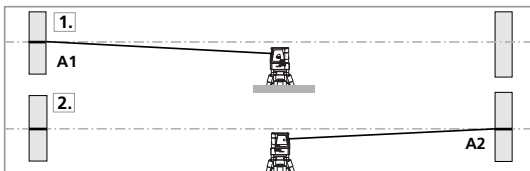

Performing the calibration check

- 3 Position the device as near as possible to the wall at the height of point A1. Adjust the device in the X axis.
- 4 Turn the device through 180° and mark point A3. The difference between points A2 and A3 is the tolerance for the X axis (P. 9).
- 5 If points A2 and A3 are more than 2 mm / 10 m apart the device is in need of calibration. Remove cover for laser calibration and adjust laser to point A2 using enclosed allen wrench.
- 6 To check the Y axis, repeat steps from 3 to 5. Calibrating the X- **and** Y-axis automatically also calibrates Z-axis.

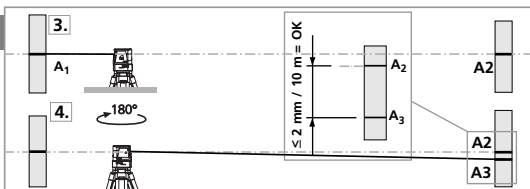

Note: An absolute calibration is only possible in a specialist workshop. Calibration by yourself is only approximate and the accuracy of the calibration will depend on the care with which you proceed. Please contact your authorised dealer or else the UMAREXLASERLINER Service Department.